

# NOKKA

*Metsäperävaunut ja kuormaimet*



*Aika koneita.*

SMART  
SARJA



## Aika koneita.

Kokoa Smart-sarjasta haluamasi yhdistelmä.  
Toimitamme koneen toiveidesi mukaan.

### Kuormain HK 1042

- Laippakiinnitteinen hydraulijatkella 4.2 m

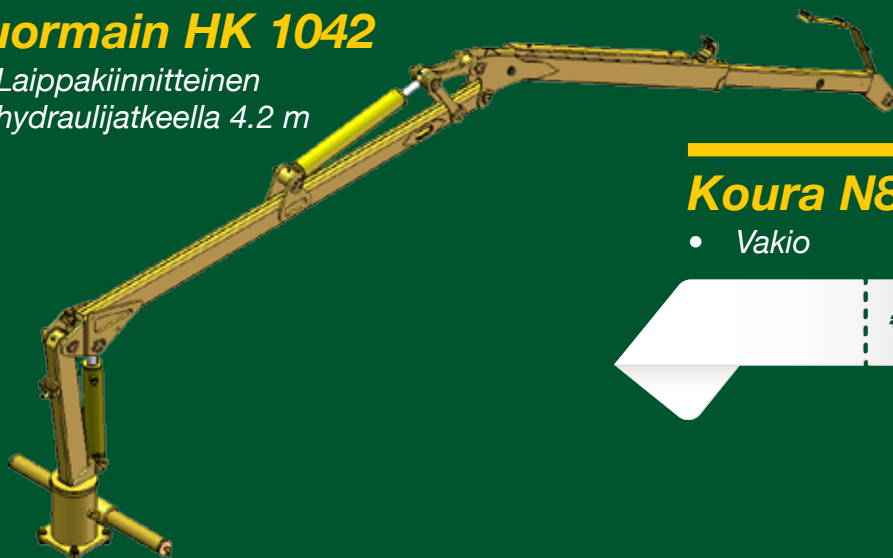

### Koura N8, kääntäjä NR1

- Vakio



### Venttiilistö

- Vakio



### 3-piste laippa-adaptteri

- Laippakuormaimelle  
3-piste -kiinnitys CAT 1

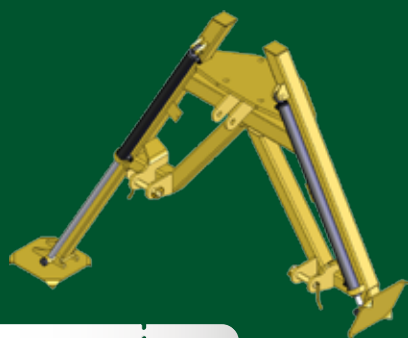

### Kiinnityslaite-etusermi-tukijalat

- Laippakuormaimelle  
kiinnityslaite vaunuihin



## MV 106 ilman sermiä

- Vaunun runko mekaanisesti siirrettävissä

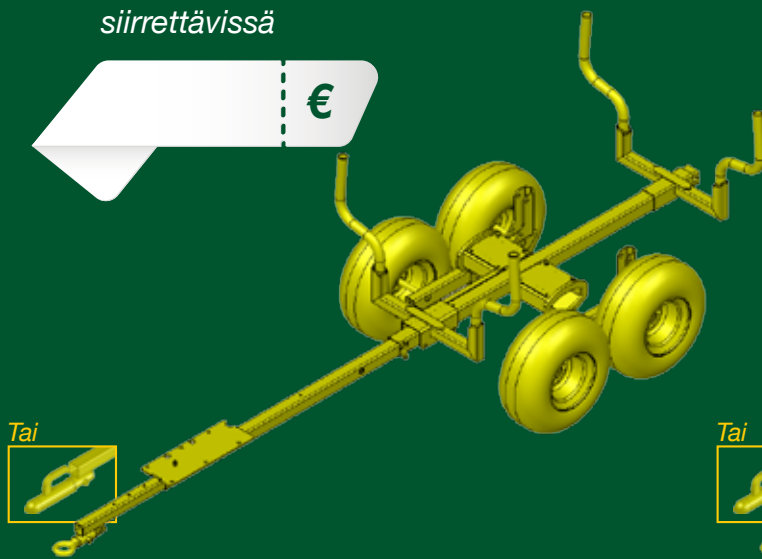

## MV 106HD ilman sermiä

- Kuvan vaunun rungossa hydraulinen jatke

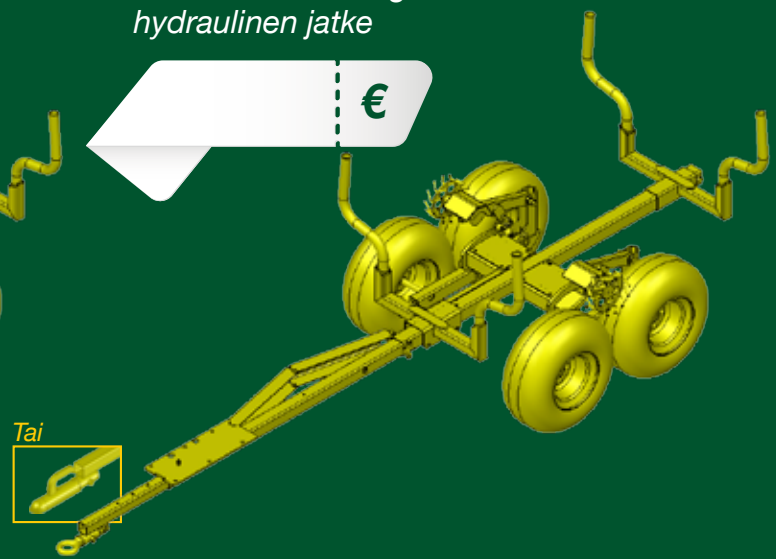

## MV 106, vaunu ilman vetoa

- Kiinnityslaitte-etusermi-tukijalat

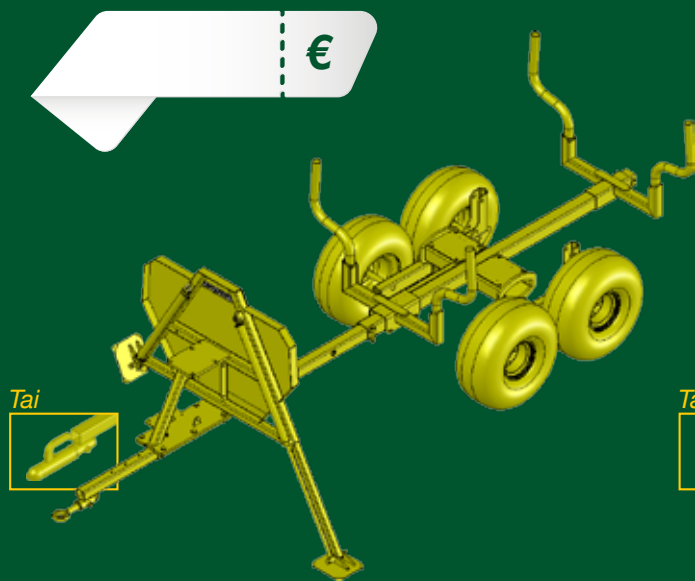

## MV 106HD, vetävä vaunu

- Kiinnityslaitte-etusermi-tukijalat

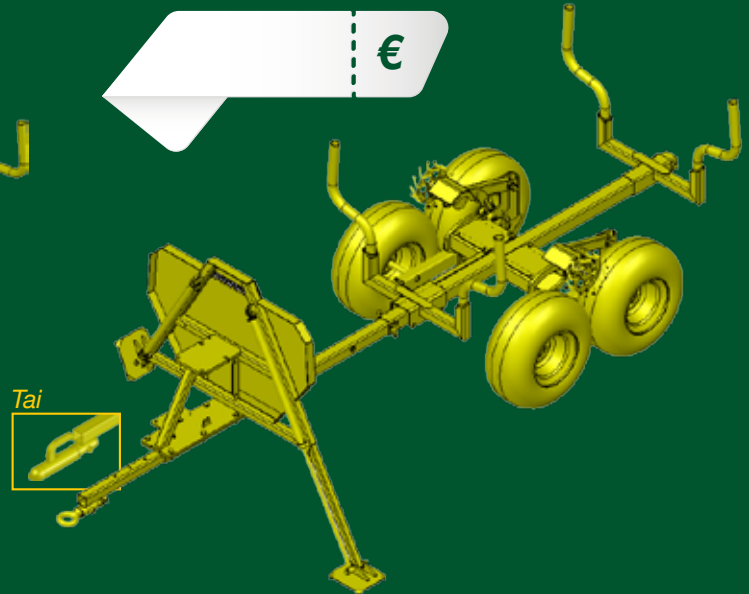

## Vetorullamodulit

- Jälkiasennus MV 106 vaunuun



## Aggregaatti



## Perävaunut

SMART sarja	MV 106	MV 106 HD
Paino ilman kuormainta, kg	300	345
Kantavuus (0-25km/h)	1000	1000
Kantavuus (25-45km/h)	290	290
Kokonaispaino, kg	1300	1345
Leveys, cm	130	130
Pituus, cm	285-430	285-430
Kuormatilan pituus, cm	187+100	187+100
Kuormausala, m <sup>2</sup>	0,65	0,65
Maavara, cm	33	33
Karikat	2 paria	2 paria
Perusrenkaat	22*11.00-8/4PR D-928	22*11.00-8/4PR D-928
Veto	veto lisävarusteena	4WD vakiona
Hydrauliikka	Traktorin hydrauliikkajärjestelmästä tai aggregaatista.	
Pumpun tuottotarve l/min	9	9
Työpaine, bar	175	175

## Kuormaimet

SMART sarja	HK 1042
Paino puutavarakouralla, kg	250
Brutto nostomomentti, kNm	10
Netto nostomomentti, kNm	7,6
Kääntömomentti, kNm	2,1
Puomin kääntökulma	220
Max. ulottuvuus, m	4,2
Max. työpaine, bar	175
Min. pumpun tuotto, l/min	9
Kääntölaite	Hammastanko 2-sylinterinen
Jatkeen pituus, m	0,8
Nostokyky ilman kouraa ja kääntäjää 2m, kg	400
Nostokyky max. ulottuvuudella, kg	165

**NOKKA Oy** Aika koneita.

Nokka Oy

40950 Muurame

Puh. 044 762 4500

Faksi (014) 310 0205

Sähköposti: nokka@nokka.fi

www.nokka.fi

## Lisävarusteet



Kippilava



Sorakahmari



Hydraulinssi



Työvalot



Energiakoura



Kaasuvipu



Sähköstartti

