



GENERAL PURPOSE GASOLINE ENGINE
120/160/200

-1-

PREFACE:

- Thank you for purchasing this engine.
- This manual covers the operation and maintenance of your engine: 120 / 160 / 200
- All information in this publication is based on the latest product information available at the time of printing.
- We reserves the right to make changes at any time without notice and without incurring any obligation.
- No part of this publication may be reproduced without written permission.
- This manual should be considered a permanent part of the engine and should remain with it if it is resold.
- Pay special attention to statements preceded by the following words:

WARNING Indicates a strong possibility of severe personal injury or death if instructions are not followed.

CAUTION Indicates a possibility of personal injury or equipment damage if instructions are not followed.

NOTE Indicates that equipment or property damage can result if instructions are not followed.

NOTE Gives helpful information.
If a problem should arise, or if you have any questions about your engine, consult an authorized dealer.

-2-

1. SAFETY INSTRUCTIONS

WARNING



To ensure safe operation-
The engine is designed to give safe and dependable service if operated according to instructions. Read and understand the Owner's Manual before operating the engine. Failure to do so could result in personal injury or equipment damage.

- Always make a pre-operation inspection (page 6) before you start the engine. You may prevent an accident or equipment damage.
- To prevent fire hazards and to provide adequate ventilation, keep the engine at least 1 meter(3 feet) away from buildings and other equipment during operation. Do not place flammable objects close to the engine.
- Children and pets must be kept away from the area of operation due to a possibility of burns from hot engine components or injury from any equipment the engine may be used to operate.
- Know how to stop the engine quickly, and understand the operation of all controls. Never permit anyone to operate the engine without proper instructions.

-3-

- Do not place flammable objects such as gasoline, matches, etc., close to the engine while it is running.
 - Refuel in a well-ventilated area with the engine stopped. Gasoline is highly flammable and explosive under certain conditions.
 - Do not overfill the fuel tank. There should be no fuel in the filler neck.
- Make sure that the filler cap is closed securely.
- If any fuel is spilled, clean it up completely and allow gasoline vapour dissipate before starting the engine.
 - Do not smoke or allow flames or sparks where the engine is refueled or where gasoline is stored.
 - Exhaust gas contains poisonous carbon monoxide. Avoid inhalation of exhaust gases. Never run the engine in a closed garage or confined area.
 - Place the engine on a stable surface. Do not tilt the engine more than 20° from horizontal. Operating at excessive angles may result in fuel spillage.

-4-

WARNING

To ensure safe operation-
■ Do not place anything on the engine, as it may create a fire hazard.
■ The muffler becomes very hot during operation and remains hot for a while after stopping the engine. Be careful not to touch the muffler while it is hot. To avoid severe burns or fire hazards, let the engine cool before transporting it or storing it indoors.

SAFETY LABEL LOCATION —

This label warns you of potential hazards that can cause serious injury. Read it carefully.
If the label comes off or becomes hard to read, contact your dealer for replacement.

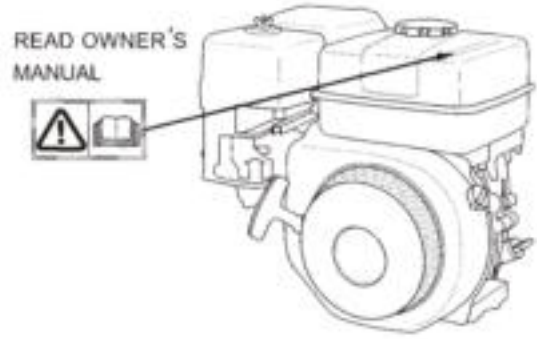

-5-

2. PRE-OPERATION CHECK

CAUTION

- Running the engine with insufficient oil can cause serious engine damage.
- Be sure to check the engine on a level surface with the engine stopped.

1. Engine oil level

- Remove the oil filler cap and wipe the dipstick clean.
- Insert the dipstick into the oil filler neck, but do not screw it in.
- If the level is low, fill to the top of the oil filler neck with the recommended oil.

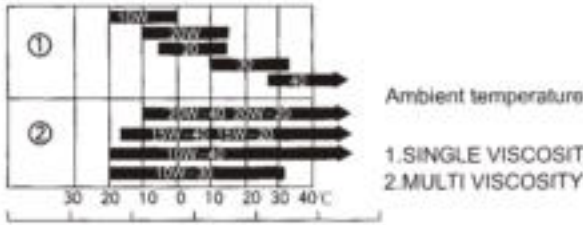

NOTE: Use 4-stroke, or an equivalent high detergent, premium quality motor oil certified to meet or exceed U.S. automobile manufacturer's requirements for service classification SG, SF. Motor oils classified SG, SF will show this designation on the container.

■ SAE 10W-30 is recommended for general, all temperature use. If single viscosity oil is used, select the appropriate viscosity for the average temperature in your area.

-6-

CAUTION

- Using nondetergent oil or 2-stroke engine oil could shorten the engine's service life.



2. Reduction gear oil

- Check reduction gear oil level.
 - Fill with SG,SF rated engine oil, if necessary.
- (1/2 reduction with automatic centrifugal clutch)
- Remove the oil filler cap and wipe the dipstick clean.
 - Insert the dipstick into the filler neck but do not screw it in.
 - If the level is low, fill to the upper level mark with the same oil recommended for the engine.(see engine oil recommendations on page 6).

Oil capacity:0.5L

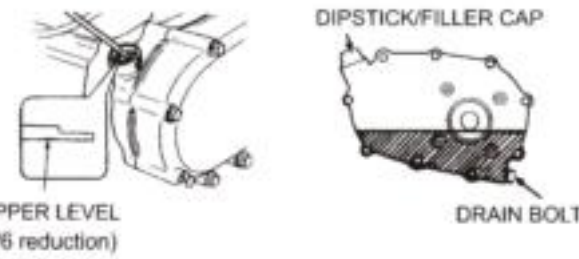

-7-

- Remove the oil level bolt.
- Check the oil level; it should reach the edge of the oil level bolt hole. If the oil level is low, remove the filler bolt, and add oil until it starts to flow out the oil level bolt hole. Use the same oil recommended for the engine.
- Install the oil level bolt and the filler bolt. Tighten them securely.

Oil capacity:0.15L



3. Air cleaner

CAUTION

- Never run the engine without the air cleaner. Rapid engine wear will result.

- (Semi-dry type) Check cleaner for dirt or obstruction of element (page 23).

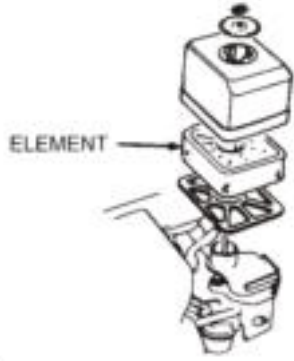

- (Oil bath type) Check the air cleaner element to be sure it is clean and in good condition. Clean or replace the element if necessary (page 23).

CAUTION

- Never run the engine without the air cleaner. Rapid engine wear will result.

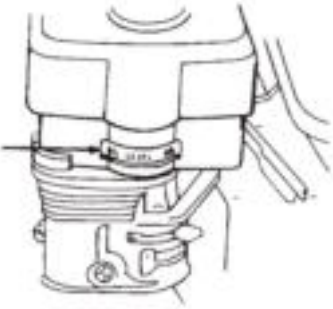

-9-

4. Fuel

- Use automotive gasoline(Unleaded or lowleaded is preferred to minimize combustion chamber deposits).

FOR NEW SOUTH WALES ONLY:
Never use an oil/gasoline mixture or dirty gasoline. Avoid getting dirt, dust or water in the fuel tank.

WARNING

- Gasoline is extremely flammable and explosive under certain conditions.
- Refuel in a well-ventilated area with the engine stopped. Do not smoke or allow flames or sparks in the area where the engine is refueled or where gasoline is stored.
- Do not overfill the fuel tank(there should be no fuel in the filler neck).
- After refueling, make sure the tank cap is closed properly and securely.
- Be careful not to spill fuel when refueling. Spilled fuel vapor may ignite.
- If any fuel spilled, make sure the area is dry before starting the engine.
- Avoid repeated or prolonged contact with skin or breathing of vapor. KEEP OUT OF REACH OF CHILDREN.

Fuel tank capacity: 120 2.5L, 160 3.6L, 200 3.6L

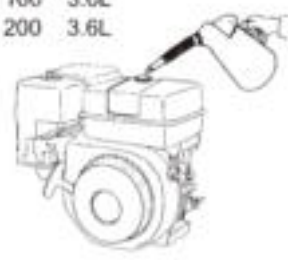

-10-

GASOLINES CONTAINING ALCOHOL

If you decide to use a gasoline containing alcohol (gasohol), be sure it's octane rating is at least as high as that recommended by your dealer. There are two types of gasohol: one containing ethanol, and the other containing methanol. Do not use gasohol that contains more than 10% ethanol. Do not use gasoline containing methanol (methyl or wood alcohol) that does not also contain cosolvents and corrosion inhibitors for methanol. Never use gasoline containing more than 5% methanol, even if it has cosolvents and corrosion inhibitors.

NOTE: Fuel system damage or engine performance problems resulting from the use of fuels that contain alcohol is not covered under the warranty. We cannot endorse the use of fuels containing methanol since evidence of their suitability is as yet incomplete.

- Before buying fuel from an unfamiliar station, try to find out if the fuel contains alcohol, if it does, confirm the type and percentage of alcohol used. If you notice any undesirable operating symptoms while using a gasoline that contains alcohol, or one that you think contains alcohol, switch to a gasoline that you know does not contain alcohol.

-11-

3. STARTING THE ENGINE

- Turn the fuel valve to the ON position.

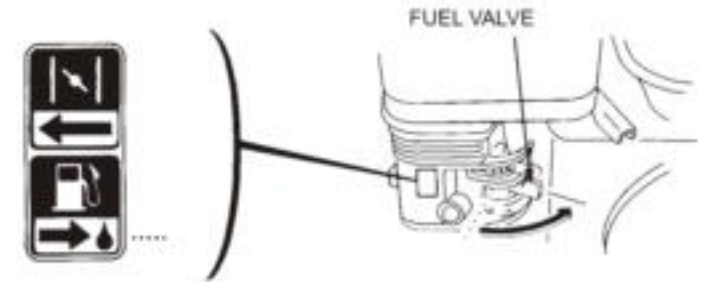

- Move the choke lever to the CLOSE position.

NOTE: Do not use the choke if the engine is warm or the air temperature is high.

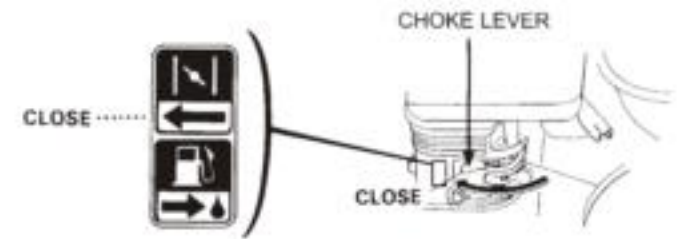

-12-

- Move the throttle control lever slightly to the left.



Start the engine

- With recoil starter: A. Turn the engine switch to the ON position B. Pull the starter grip lightly until resistance is felt, then pull briskly.

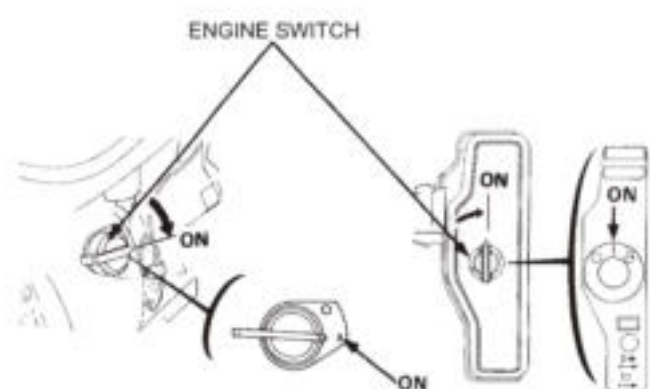

-13-

CAUTION

- Do not allow the starter grip to snap back against the engine. Return it gently to prevent damage to the starter.

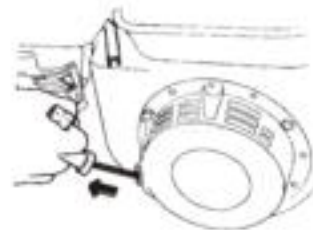

- With electric starter A. Turn the engine switch to the START position and hold it there until the engine starts. B. When the engine starts, return the switch to the ON position.

NOTE: Do not use the electric starter for more than 5 seconds at a time. If the engine fails to start, release the key and wait 10 seconds before operating the starter again.

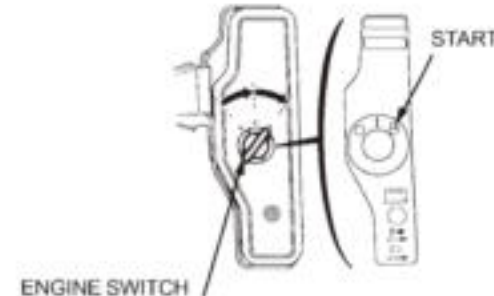

-14-

HIGH ALTITUDE OPERATION —

At high altitude, the standard carburetor air-fuel mixture will be excessively rich. Performance will decrease, and the fuel consumption will increase.

High altitude performance can be improved by installing a smaller diameter main fuel jet in the carburetor and readjusting the pilot screw. If you always operate the engine at altitudes higher than 1830m above sea level, have your authorized KAMA dealer perform these carburetor modifications.

Even with suitable carburetor jetting, engine horsepower will decrease approximately 3.5% for each 305m increase in altitude. The effect of altitude on horsepower will be greater than this if no carburetor modification is made.

CAUTION

- Operation of the engine at an altitude lower than the carburetor is jetted for may result in reduced performance, overheating, and serious engine damage caused by an excessively lean air/fuel mixture.

-15-

4. OPERATION

- As the engine warms up, gradually move the choke lever to the OPEN position.

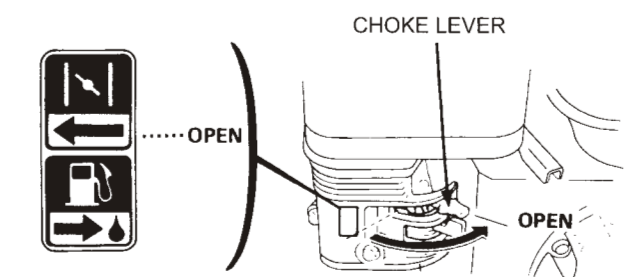

- Position the throttle control lever for the desired engine speed.

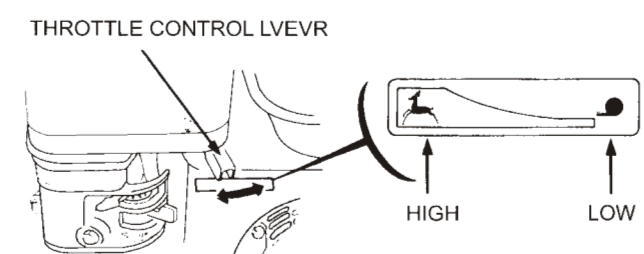

-16-

Oil Alert System (where equipped) —

The Oil Alert System is designed to prevent engine damage caused by insufficient oil in the crankcase. Before the oil level in the crankcase can fall below a safe limit, the Oil alert System will automatically stop the engine (the engine switch will remain in the ON position).

NOTE

- If the engine stops and will not restart, check the engine oil level (page 6) before troubleshooting in other areas.

Circuit Breaker (for electric starter) —

The circuit breaker protects the battery charging circuit. A short circuit or a battery connected in reverse polarity will trip the circuit breaker.

The green indicator inside the circuit breaker will pop out to show that the circuit breaker has switched off. If this occurs, determine the cause of the problem, and correct it before resetting the circuit breaker.

Push the circuit breaker button to reset.

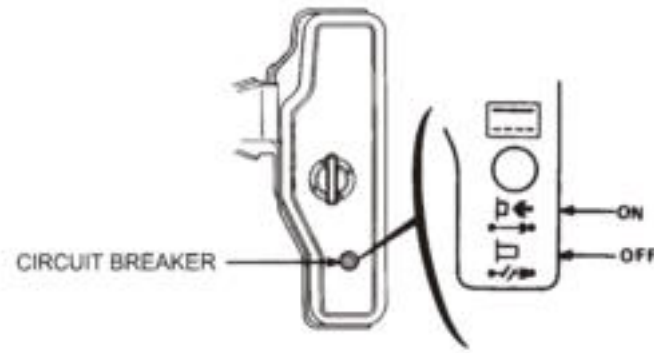

-17-

5. STOPPING THE ENGINE

- To stop the engine in an emergency, turn the engine switch to the OFF position.
- Under normal conditions, use the following procedure:

A. Move the throttle control lever fully to the right.

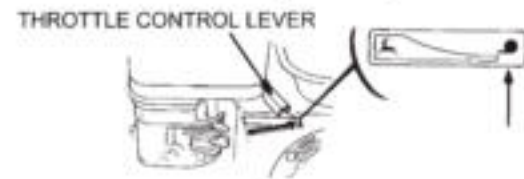

B. Turn the engine switch to the OFF position.

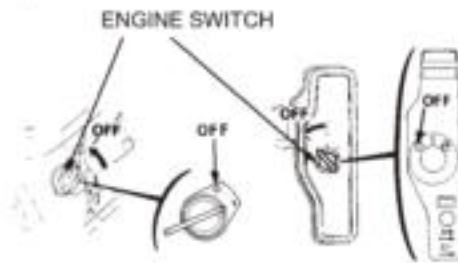

C. Turn the fuel valve to the OFF position.

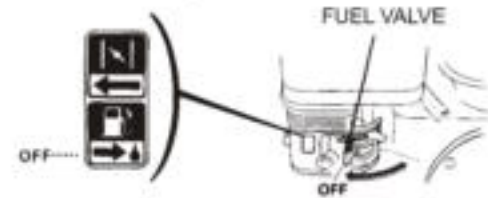

-18-

6. MAINTENANCE

WARNING

- Shut off the engine before performing any maintenance.
- To prevent accidental start-up, turn OFF the engine switch key and disconnect the spark plug caps.
- The engine should be serviced by an authorized dealer unless the owner has proper tools and service data and feels he is mechanically qualified.

CAUTION

- Use only genuine parts or their equivalent. The use of replacement parts which are not of equivalent quality may damage the engine.
- Periodic inspection and adjustment of the engine is essential if high level performance is to be maintained. Regular maintenance will also ensure a long service life. The required service intervals and the kind of maintenance to be performed are described on the below table.

MAINTENANCE SCHEDULE

REGULAR SERVICE PERIOD	Each use	First month or 20 Hrs.	Every 3 months or 50 Hrs.	Every 6 months or 100 Hrs.	Every year or 300 Hrs.
PERFORMED AT EVERY INDICATED MONTH OR OPERATING HOUR INTERVAL, WHICHEVER COMES FIRST					
Engine oil	Check level	○	○	○	○
Change					
Reduction gear oil (applicable models only)	Check level	○	○	○	○
Change					
Air cleaner	Check	○	○	○	○
Clean					
Sediment cup	Clean		○(1)		
Spark plug	Check-Clean			○	
Valve clearance	Check-adjust				○(2)
Fuel tank and strainer	Clean				○(2)
Fuel line	Check (Replace if necessary)				Every 2 years(2)

-19-

- NOTE:** (1) Service more frequently when used in dusty areas.
(2) These items should be serviced by an authorized dealer, unless the owner has the proper tools and is mechanically proficient. See the Shop Manual.

- Oil change
Drain the oil while the engine is still warm to assure rapid and complete draining.
A. Remove the oil filler cap and drain plug to drain the oil.
B. Install the drain plug, and tighten it securely.
C. Refill with the recommended oil (see page 6) and check the oil level.
D. Install the oil filler cap.

ENGINE OIL CAPACITY: 0.6L
1/2 REDUCTION GEAR OIL CAPACITY: 0.5L
1/6 REDUCTION GEAR OIL CAPACITY: 0.15L

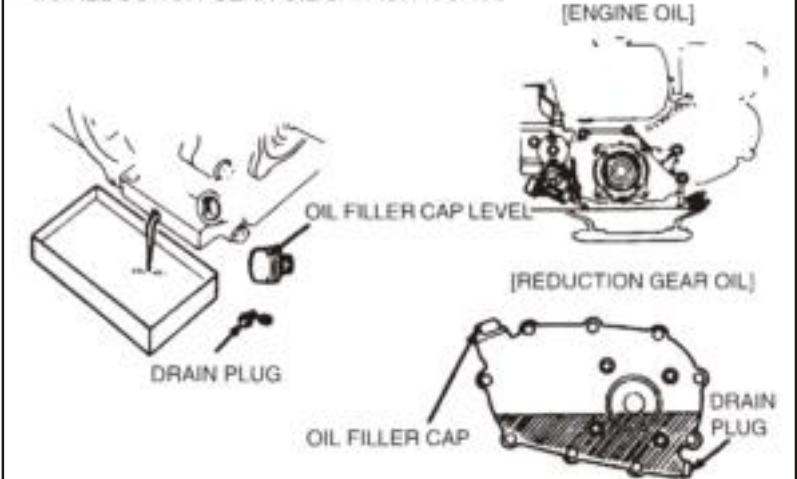

-20-

CAUTION

- Used motor oil may cause skin cancer if repeatedly left in contact with the skin for prolonged periods. Although this is unlikely unless you handle used oil on a daily basis, it is still advisable to thoroughly wash your hands with soap and water as soon as possible after handling used oil.

NOTE: Please dispose of used motor oil in a manner that is compatible with the environment. We suggest you take it in a sealed container to your local service station for reclamation. Do not throw it in the trash or pour it on the ground.

2. Air cleaner service

A dirty air cleaner will restrict air flow to the carburetor. To prevent carburetor malfunction, service the air cleaner regularly. Service more frequently when operating the engine in extremely dusty areas.

WARNING

- Never use gasoline low flash point solvents for cleaning the air cleaner element. A fire or explosion could result.

CAUTION

- Never run the engine without the air cleaner. Rapid engine wear will result.

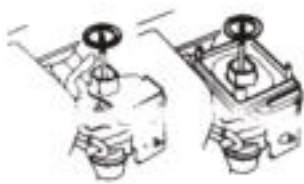

-21-

(Semi-dry type)

- Unscrew the wing nut, remove the air cleaner cover and remove the element.
- Wash the element in a nonflammable or high flash point solvent and dry it thoroughly.
- Soak the element in clean engine oil and squeeze out the excess oil.
- Reinstall the air cleaner element and the cover.

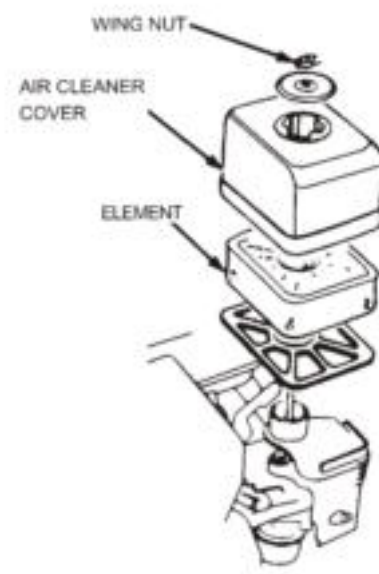

-22-

(Oil bath type)

- Unscrew the wing nut, remove the air cleaner cover and remove the element.
- Wash the element in a solution of household detergent and warm water, then rinse thoroughly, or wash in nonflammable or high flash point solvent. Allow the element to dry thoroughly.
- Soak the element in clean engine oil and squeeze out the excess oil. The engine will smoke during the initial start-up if too much oil is left in the element.
- Empty the oil from the air cleaner case and wash out any accumulated dirt with nonflammable or high flash point solvent. Dry the case.

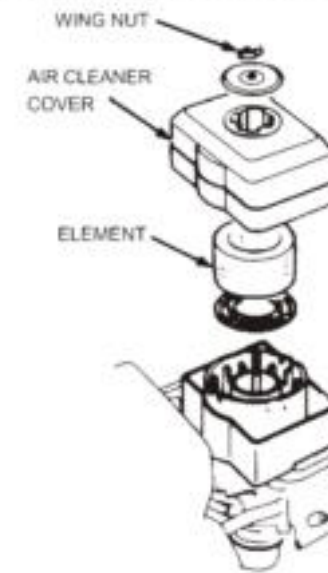

-23-

3. Sediment cup cleaning

WARNING

- Gasoline is extremely flammable and explosive under certain conditions. Do not smoke or allow flames or sparks in the area.
- After installing the sediment cup, check for leaks, and make sure the area is dry before starting the engine.

Turn the fuel valve to OFF, Remove the sediment cup and O-ring, and wash them in nonflammable or high flash point solvent.

Dry them thoroughly and reinstall securely.

Turn the fuel valve ON and check for leaks.

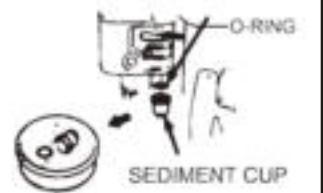

4. Spark plug service

Recommended spark plug: BP6ES

CAUTION

- Never use a spark plug with incorrect heat range.

WARNING

- If the engine has been running, the muffler will be very hot. Be careful not to touch the muffler.

To ensure proper engine operation, the spark plug must be properly gapped and free of deposits.

(1) Remove the spark plug cap and use the proper size spark plug wrench to remove the spark plug.



-24-

(2) Visually inspect the spark plug. Discard the spark plug if there is apparent wear, or if the insulator is cracked or chipped. Clean the spark plug with a wire brush if it is to be reused.

(3) Measure the plug gap with a feeler gauge. Correct if necessary by bending the side electrode.
The gap should be:
0.70-0.80mm (0.028-0.031 in)

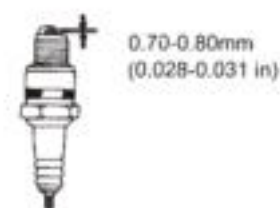

(4) Check that the spark plug washer is in good condition and thread the spark plug in by hand to prevent cross-threading.
5. After the spark plug is seated, tighten with a spark plug wrench to compress the washer.



-25-

NOTE: When installing a new spark plug, tighten 1/2 turn after the spark plug seats to compress the washer. When reinstalling a used spark plug, tighten 1/8-1/4 turn after the spark plug seats to compress the washer.

CAUTION

- The spark plug must be securely tightened. An improperly tightened spark plug can become very hot and may damage the engine.

5. Carburetor idle speed adjustment

- Start the engine and allow it to warm up to normal operating temperature.
- With the engine idling, turn the throttle stop screw to obtain the standard idle speed.

Standard idle speed: 1400 ± 140 r/min.

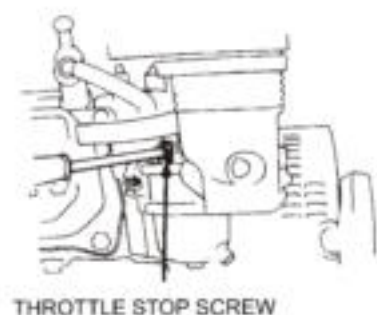

-26-

7. TRANSPORTING/STORAGE

WARNING

- When transporting the engine, turn the fuel valve OFF and keep the engine level to prevent fuel spillage. Fuel vapor or spilled fuel may ignite.

WARNING

- Gasoline is extremely flammable and explosive under certain conditions. Do not smoke or allow flames or sparks in the area.
- A. With the fuel valve in the OFF position, remove and empty the sediment cup.
- B. Turn the fuel valve to the ON position and drain the gasoline from the fuel tank into a suitable container.
- C. Replace the sediment cup and tighten securely.
- D. Drain the carburetor by loosening the drain screw. Drain the gasoline into a suitable container.

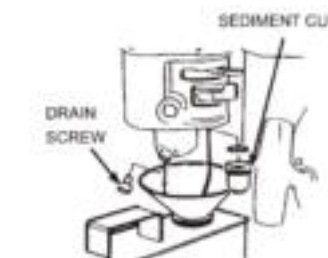

-27-

Before storing the unit for an extended period:

- Be sure the storage area is free of excessive humidity and dust.
- Drain the fuel...
- Change the engine oil (page 20)
- Remove the spark plug and pour about a tablespoon of clean engine oil into the cylinder.
Crank the engine several revolutions to distribute the oil, then reinstall the spark plug.
- Pull the starter rope slowly until resistance is felt. Continue pulling until the notch on the starter pulley aligns with the hole on the recoil stator (see illustration below). At this point, the intake and exhaust valves are closed, and this will help to protect the engine from internal corrosion.



F. Cover the engine to keep out dust.

-28-

8. TROUBLESHOOTING

1. Difficult starting or failed starting

Cause	Remedy
Improper operation	Operating following the operation manual
No fuel oil	Fuel tank is empty: Refuel the fuel oil Fuel tank switch is OFF or the carburetor is clogged: Clean the fuel line
Insufficient engine oil	Refill the engine oil
Malfunction of the spark plug	Deposit carbon: Clean up the deposit carbon and wash the spark plug with gasoline
	Insulating block damaged: Replace Improper electrode clearance: Readjust
Low cylinder pressure	Air leakage of the spark plug: Tighten the spark plug
	Air leakage between the cylinder block and the cover: Clean off the surface, assemble the washer and tighten the bolt.
	Seriously worn of the piston ring or the cylinder block: Replace the piston ring or the cylinder block
	Piston ring broken up or clogged by the deposit carbon: Replace the piston ring or clean it and the deposit carbon

2. Imperfect engine idle speed

Cause	Remedy
No idle speed	Improper adjustment of the carburetor: Adjust the carburetor Fuel line and air line clogged: Clean the fuel line and air line
High idle speed	The diameter of the main fuel jet is too large: Replace the carburetor
Unsteady idle speed	Air-fuel mixture is too rich or too poor: Adjust the carburetor
	Air cleaner clogged: Clean the air cleaner The spark plug clearance is too big: Adjust the clearance

-29-

3. Rough running of the engine

Cause	Remedy
Leakage of the high voltage cable	Replace
Too many carbon between the spark plug electrodes	Clean up the carbon
Fuel line clogged	Clean the fuel line

4. Engine is too hot

Cause	Remedy
Cylinder radiator has oil or mud contamination	Clean up
Temperature is too high or long time running with surcharge load	Stop the engine, restart it after cooling
Muffler clogged	Clean up the deposit carbon
Fuel's octane rating is too low	Use the recommend fuel oil
Lube oil do not meet the specification	Replace the lube oil

5. Automatically halting of the engine

Cause	Remedy
Fuel is up or engine oil is insufficient	Refill the fuel oil or engine oil
Fuel can't delivery to the fuel line or the carburetor clogged	Clean the fuel line and carburetor
Malfunction of the ignition system	Inspect the circuit
Other mechanical clogging fault	Repair or replace after inspection

-30-

9. SPECIFICATIONS

1. Main specifications

Model	120	160	200
Type	4-stroke air-cooled OHV single cylinder gasoline engine		
Bore × Stroke(mm)	60 × 42	68 × 45	68 × 54
Displacement(L)	0.118	0.163	0.196
Max power kW(PS)/min	2.9(4.0)/3600	3.6(4.9)/3600	4.4(6.0)/3600
Rated power kW(PS)/min	2.6(3.5)/3600	3.3(4.5)/3600	4.0(5.5)/3600
Fuel	Unleaded automotive gasoline		
Fuel tank capacity (L)	2.5	3.6	
Fuel consumption (g/PS.h)	275		
Lube oil	SAE 10W30		
Lube oil capacity (L)	0.6		
Starting system	Recoil starter		
Ignition system	Transistorized magneto ignition		
Spark plug	BP6ES		
Governor system	Mechanical		
Rotating direction of output shaft	Clockwise viewed from the flywheel end		
Dimension(mm) (L × W × H)	300 × 345 × 320	305 × 365 × 335	313 × 376 × 335
Dry weight(kg)	12	14	16

-31-

2. Valve clearance

Model	120	160	200
Inlet valve(mm)	0.10 ± 0.02		
Exhaust valve(mm)	0.15 ± 0.02		

3. Tightening torque of main bolt and nut

No.	Name	Unit: N.m
1	Connecting rod bolt	14 ^{1/2}
2	Cylinder head bolt	30 ± 2
3	Flywheel nut	80 ^{1/2}
4	Rocker arm pivot bolt	24 ^{1/2}
5	Crankcase cover bolt	23 ^{1/2}
6	Spark plug	25 ± 2
7	Standard M6 bolt(nut)	10 ^{1/2}

NOTE: Specifications may vary with the types, and are subject to change without notice.

-32-